

Operating instructions

DIQS10 | DWQS6 | DWQS7 | DWQS9

Range hood

Thank you for choosing to buy one of our products. Your appliance is made to high standards and is easy to use. Nevertheless, please take the time to read these operating instructions in order to familiarize yourself with the appliance and get the best use out of it.

Please follow the safety precautions.

Modifications

Text, diagrams and data correspond to the technical standard of the appliance at the time these operating instructions went to press. The right to make technical modifications for the purpose of the further development of the appliances is reserved.

Validity

These operating instructions apply to:

Type	Model number	Size system
DIQS10	63014	100
DWQS6	62019	60
DWQS7	62020	70
DWQS9	62021	90

Variations depending on the model are noted in the text.

Contents

1	Safety precautions	4	Index	22	
1.1	Symbols used.....	4	9	Service & Support	23
1.2	General safety precautions.....	4			
1.3	Appliance-specific safety precautions	5			
1.4	Appliance installation	5			
1.5	Instructions for use.....	6			
2	Appliance description	8			
2.1	Introduction	8			
2.2	Extraction mode.....	8			
2.3	Recirculation mode with activated charcoal filter 8				
2.4	Features.....	8			
2.5	Construction	8			
2.6	Operating and display elements.....	9			
3	Operating the appliance	10			
3.1	Using for the first time	10			
3.2	Switching the appliance on/off	10			
3.3	Illumination.....	10			
3.4	Power level.....	11			
3.5	Intensive level.....	11			
3.6	After-running time	11			
3.7	CleanAir.....	12			
3.8	Saturation indicator alarm.....	12			
3.9	Remote control (accessories).....	13			
4	Care and maintenance	15			
4.1	Cleaning the housing.....	15			
4.2	Metal grease filters.....	15			
4.3	Standard activated charcoal filter.....	16			
4.4	Long-life activated charcoal filters.....	17			
4.5	Reset saturation indicator alarm.....	18			
4.6	Replacing the LED light bulbs.....	18			
5	Trouble-shooting	18			
6	Accessories and spare parts	19			
7	Technical data	19			
7.1	Product fiche	20			
8	Disposal	21			

1 Safety precautions

1.1 Symbols used



Denotes important safety precautions.

Failure to observe said precautions can result in injury or in damage to the appliance or fittings!



Information and precautions that should be observed.



Information on disposal



Information about the Operating Instructions



Remove plug from mains socket / disconnect power supply



Insert plug into mains socket / connect power supply



Do not cut off or modify mains plug



Wear protective gloves

- ▶ Indicates step-by-step instructions.
 - Describes how the appliance reacts to the steps taken.
- Indicates a list.

1.2 General safety precautions



- Read the operating instructions before using the appliance for the first time.



- This appliance can be used by children aged 8 and above and by persons with reduced physical, sensory or mental capabilities, or lack of experience and/or knowledge, provided they are supervised or have been instructed on the safe use of the appliance and have understood the hazards involved. Children shall not play with the appliance. Cleaning and user maintenance shall not be undertaken by children without supervision.
- If an appliance is not equipped with a mains cable and a plug or other means for disconnecting from the mains with a contact opening on each pole complying with the conditions of overvoltage category III for full isolation, an isolating device must be incorporated into the permanently installed electrical installation in accordance with the installation regulations.
- If the mains cable of this appliance is damaged, it must be replaced by the manufac-

turer or its Customer Services or a similarly qualified person in order to avoid hazard.

1.3 Appliance-specific safety precautions

- The room must be adequately ventilated when operating the range hood at the same time as other appliances that burn gas or other fuels.
- Observe the official regulations for the exhaust-air layout.
- The extracted air must not be fed into a chimney which is used for exhausting fumes from appliances burning gas or other fuels.
- The minimum distance between the supporting surface for the cooking equipment on the hob and the lowest part of the range hood must be observed. See the installation instructions for this.
- **WARNING:** Before replacing the light bulb, ensure the appliance is switched off and disconnected from the mains power supply to avoid possible electric shock.
- When replacing a light bulb, the maximum wattage rating of replaceable light bulbs must be visible.

- This appliance is intended for use in the home and similar settings such as: in staff kitchens in shops, offices and other commercial establishments; in agricultural establishments; by guests in hotels, motels and other accommodation establishments; in bed and breakfast establishments.
- Do not operate the appliance using an external time switch or a separate remote control system.
- Failure to follow the cleaning instructions may cause a fire hazard.
- Do not flambé food underneath the range hood.

1.4 Appliance installation



- The appliance must be installed by qualified personnel only.
- Each step must be carried out and checked in full in the order specified.
- Electrical connections must be carried out by qualified personnel in accordance with the guidelines and standards for low-voltage installations and the specifications of the local electricity supply companies.
- A plug-in appliance may only be connected to a socket outlet with earthing contact, installed according to specifications. An all-pole mains isolating device with 3 mm contact opening should be provided in the house wiring system. Switches, plug and socket devices, circuit breakers and fusible cut-outs which are accessible after installation and

which have all-poles switching are permissible as isolating devices. Effective earthing and separately installed neutral and earth conductors ensure safe and fault-free operation. After installation, live parts and cables with basic insulation must not be accessible. Check old installations.

- Refer to the identification plate for information on the required mains voltage, current type and fuse protection.
- All plastering, plasterboarding, wall papering and painting work is to be carried out prior to installing the appliance.
- Efficient repairs can only be guaranteed if it is possible to de-install the complete appliance at any time without causing any damage.

1.5 Instructions for use

Before using for the first time

- The appliance must be installed and connected to the electricity supply in accordance with the separate installation instructions. Have a qualified fitter/ electrician carry out the necessary work.
- Observe the official regulations for the exhaust-air layout.
- Dispose of the packaging material in accordance with local regulations.

Correct use

- The appliance is designed for use in the home for extracting cooking fumes and smells from above the cooking surface.
- Any repairs, modifications or manipulations to the appliance, especially any electrically live parts, may only be carried out by the manufacturer, its customer service department or similarly qualified persons. Repairs if carried out incorrectly may cause serious injury, damage to the appliance and fittings,

as well as affect the functioning of the appliance. If the appliance is not working properly or in case a repair is needed, follow the instructions given in the 'Service & Support' section. Contact our Customer Services if necessary.

- Use original spare parts only.
- Retain these operating instructions for future reference.

Note on use

- If the appliance is visibly damaged, do not use it. Contact our Customer Services.
- If the appliance is not functioning properly, disconnect it from the power supply immediately.
- Ensure there is adequate ventilation when the extractor fan is on so as to avoid creating underpressure in the kitchen and to achieve optimal air extraction.
- Avoid a cross-current of air, which could blow the cooking vapours over the cooking area.
- If other appliances – fired by gas or other fuels – are being used at the same time, ensure that there is a sufficient supply of fresh air. This does not apply to air recirculation appliances.
- If other firing systems are being used at the same time (e.g. wood, gas, oil or coal fired heating appliances), safe operation is only possible providing a room negative pressure of 4 Pa (0.04 mbar) is not exceeded at the location of the appliance. Risk of toxic fumes! An adequate flow of fresh air must be guaranteed e.g. via non-closable openings in doors or windows and in combination with an air-intake/exhaust-air wall box or by other technical means.
- When cleaning the appliance make sure no water gets inside it. Use a moderately damp cloth only. Do not spray the inside or outside of the appliance with water. Do not use a steam cleaner. If water gets inside the appliance, it can cause damage.

- Accessible parts may become hot when used with cooking appliances.

Caution: Burns hazard!

- Do not leave the appliance unattended when deep-frying on the cooking surface. The cooking oil in the deep-frying appliance could overheat and catch fire. Constantly monitor the temperature of the cooking oil, keeping it below the temperature at which it can catch fire. Change the cooking oil regularly – dirty oil catches fire more easily than clean oil.

Caution: Risk to life!

- Packaging material, e.g. plastic film and polystyrene, can be dangerous for children and animals. Danger of suffocation! Keep packaging material away from children and animals.
- When carrying out maintenance work on the appliance, including replacing light bulbs, cut off the electricity supply to the appliance: remove the screw fuse from the holder or switch the circuit breaker off, or disconnect from the mains supply.

How to avoid damaging the appliance

- Observe the cleaning intervals. Failure to do so can increase the fire hazard due to the build-up of grease in the metal grease filters.

2 Appliance description

2.1 Introduction

The appliance is designed for use in the home for extracting cooking odours from above a cooking area and can be used in the extraction or recirculation mode.



Extraction mode



Recirculation mode

2.2 Extraction mode

A fan extracts cooking fumes and smells from above the cooking surface. The metal grease filters clean the extracted air, which is then passed through a connecting pipe fitted with an integrated non-return valve and through the air duct to the outside.



When in use, ensure there is a sufficient supply of fresh air to replace the air that is being extracted.

2.3 Recirculation mode with activated charcoal filter

A fan extracts cooking fumes and smells from above the cooking surface. The air is passed through the metal grease filter and activated charcoal filter, grease particles and odours are largely removed from the air and it is then circulated back into the room.



If activated charcoal filters are not supplied with the appliance, these should be ordered and installed before using the appliance for the first time.

2.4 Features

- 1 hood body is equipped with: extractor fan, LED lighting, operating and display elements, metal grease filters
- Casing
- Installation material
- Activated charcoal filter for recirculation mode (not included in the scope of delivery, available as an accessory)

2.5 Construction



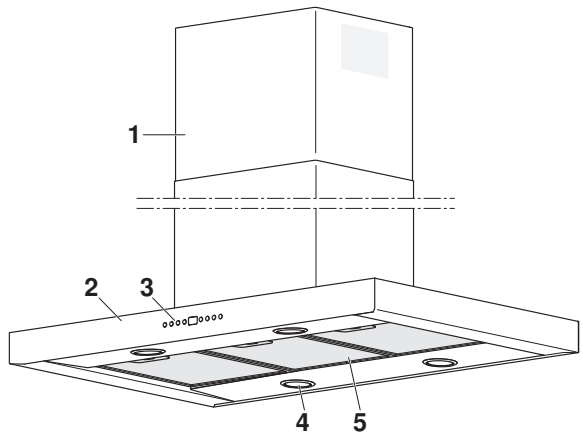





- 1 Casing
- 2 Hood body
- 3 Operating and display elements
- 4 Illumination with cover
- 5 Metal grease filters











2.6 Operating and display elements



Buttons

-  Switch appliance on/off
-  Decrease power level
-  Increase power level
-  Intensive power level; alarm for activated charcoal filter on/off
-  CleanAir function; reset saturation indicator
-  After-running time; activate remote control
-  High intensity illumination
-  Low intensity illumination

Display field

-  Power level (1–3)
-  Intensive level
-  Switch between extraction/recirculation mode; alarm for activated charcoal filter on/off
-  CleanAir function active
-  Reset saturation indicator alarm
-  Saturation indicator for metal grease filters
-  Saturation indicator for activated charcoal filter (recirculation mode only)
-  Remote control on/off



Depending on the model and features, the specification of your appliance may differ in individual details from the standard specification described.

3 Operating the appliance

The appliance can be operated using the operating and display elements on the appliance or the remote control (available as an accessory).

3.1 Using for the first time

Appliance configuration

The model can be used to extract or recirculate air. The appliance is set up ex-factory for use in the extraction mode.



Setting up the appliance for use in the recirculation mode

- ▶ Switch the appliance and the illumination off.
- ▶ Hold the  button depressed for 5 seconds.
 - **FC** appears in the display with a dot that flashes **twice**.
 - The appliance is now configured for the recirculation mode and the saturation indicator for the activated charcoal filter is activated.





Setting up the appliance for use in the extraction mode

- ▶ Switch the appliance and the illumination off.
- ▶ Hold the  button depressed for 5 seconds.
 - **FC** appears in the display with a dot that flashes **once**.
 - The appliance is now configured for the extraction mode and the saturation indicator for the activated charcoal filter is deactivated.

3.2 Switching the appliance on/off

- ▶ Touch the  button.
 - The appliance switches on at power level 1.
- ▶ Touch the  button again.
 - The appliance switches off.



3.3 Illumination

- ▶ Touch the  or  button.
 - The illumination switches on at the selected light intensity.
- ▶ Touch the previously selected button  or  again.
 - The illumination switches off.





The illumination can be used independently of the extractor fan.

Changing the light intensity

- ▶ Touch the  button.
 - The illumination switches on at high intensity.
- ▶ Touch the  button.
 - The illumination switches on at low intensity.

3.4 Power level

- ▶ Touch the  button.
 - The next highest power level switches on.
- ▶ Touch the  button.
 - The next lowest power level switches on.
 - The corresponding power level appears in the display.





The intensive power level cannot be selected using the  button.

3.5 Intensive level

The intensive power level can run for 6 minutes. It is used for short bursts of intensive extraction of cooking fumes and smells, e.g. when searing meat. The intensive power level then switches back to the previously selected power level or switches the appliance off.

Switching on

- ▶ Touch the  button.
 - The appliance switches the intensive power level on for 6 minutes.
 -  and the time remaining alternate in the display.
- If another power level had been running beforehand, then the appliance will automatically revert to this power level after 6 minutes has elapsed.
- If no power level had been running when the intensive level was selected, the appliance will switch off after 6 minutes.



Ending before time

- ▶ While the intensive power level is active, touch the  button.
 - The intensive level switches off before time.
 - The appliance switches back to the previously selected power level or switches off.



3.6 After-running time

The purpose of the after-running time function is to remove any lingering smells after cooking. The appliance continues to run at the power level set for 30 minutes and then switches off automatically.

Switching on

- ▶ Switch the appliance on and touch the  or  button repeatedly until the desired power level is reached.
- ▶ Touch the  button.
 - The after-running time function switches on and the corresponding power level appears in the display.
 - A dot in the display flashes once a second when the after-running time function is active.

Ending before time

- ▶ Touch the  button again to end the after-running time function.
 - The after-running time function ends.
 - The appliance switches back to the previously selected power level.
- ▶ Touch the  button.
 - The appliance switches off.



The after-running time function cannot be activated with the intensive power level or the CleanAir function.

3.7 CleanAir

The CleanAir function cleans (recirculation mode) or extracts (extraction mode) the air periodically. This runs every hour for 10 minutes on power level 1. The CleanAir function switches off after 24 hours.

Switching on



The CleanAir function cannot be activated with the intensive power level or the after-running time function.

- ▶ Touch the  button.
 - The CleanAir function switches on and **24** appears in the display.
 - A dot in the display flashes once a second when the CleanAir function is active.

Ending before time

- ▶ Touch the  button again to end the CleanAir function.
 - The CleanAir function switches off.

3.8 Saturation indicator alarm

Metal grease filters

After 100 operating hours, **FG** appears in the display when the appliance is switched off. The saturation level has been reached and the metal grease filters must be cleaned.

Activated charcoal filter (recirculation mode only)

After 200 operating hours, **FC** appears in the display when the appliance is switched off. The saturation level of the activated charcoal filter has been reached. The activated charcoal filter has to be cleaned and regenerated or replaced. Metal grease filters have also to be cleaned. Observe the cleaning instructions.

Reset the saturation indicator alarm after cleaning.







- ▶ Switch the appliance and the illumination off.
- ▶ Hold the  button depressed for 3 seconds.
 - **FF** flashes **thrice** in the display.
 - Saturation indicator alarm **FG** or **FC** goes out.



Only activate the saturation indicator for the activated charcoal filter if the appliance is being used in the recirculation mode. For more details, see: Using for the first time (see page 10).

3.9 Remote control (accessories)

This appliance can be controlled by a remote control (available for order as an accessory), which requires two 3V CR2032 batteries (supplied with the remote control).

-  Switch appliance on/off
-  Increase power level
-  Decrease power level
-  Switch intensive level on/off
-  Switch illumination on/off, change light intensity
-  Switch after-running time on/off
-  No function / Not activated



-  **Do not place the remote control near any heat sources.**
- Dispose of the batteries at a suitable recycling point in accordance with national regulations.**



Activating the remote control

- ▶ Switch the appliance and the illumination off.
- ▶ Hold the  button on the appliance depressed for five seconds.
 - **IR.** appears in the display with a dot that flashes **twice**.
 - The appliance can now be operated using the remote control.



Deactivating the remote control

- ▶ Switch the appliance and the illumination off.
- ▶ Hold the  button depressed again for five seconds.
 - **IR.** appears in the display with a dot that flashes **once**.
 - The remote control is deactivated.



Switching the appliance on/off

- ▶ Touch the  button.
 - The appliance switches on at power level 1.
- ▶ Touch the  button again.
 - The appliance switches off.

Switching the illumination on/off

- ▶ Touch the  button.
 - The illumination switches on at maximum intensity.
- ▶ Touch the  button again.
 - The illumination switches off.



Changing the light intensity

- ▶ When the illumination is switched on, hold the  button depressed for two seconds.
 - The light intensity is lowered.
- ▶ When the light intensity is low, touch the  button.
 - The light intensity is increased.
- The illumination switches off if the  button has been held depressed for two seconds when the light intensity is low or if it is touched when the light intensity is high.





The illumination can be used independently of the extractor fan.





Changing the power level

- ▶ Touch the  button.
 - The next highest power level switches on.
- ▶ Touch the  button.
 - The next lowest power level switches on.



Switching intensive level on/off

- ▶ Touch the  button.
 - The intensive level switches on.
- ▶ Touch the  button again.
 - The intensive level switches off.

Switching after-running time on/off

- ▶ Switch the appliance on and select the desired power level using the  or  button.
- ▶ Touch the  button.
 - The after-running time switches on.
- ▶ Touch the  button again.
 - The after-running time switches off before time.

Switching the CleanAir function on/off

- ▶ Hold the  button depressed for 2 seconds.
 - The CleanAir function switches on.
- ▶ Hold the  button depressed again for 2 seconds.
 - The CleanAir function switches off before time.

4 Care and maintenance

4.1 Cleaning the housing



Make sure no water gets inside the appliance. If water gets into the appliance, it can cause damage.

Do not use abrasive cleaners, scouring pads, steel wool, etc. for cleaning, as they can damage the surface. Disconnect the power supply before cleaning.

Exterior

- ▶ Clean using a clean, damp cloth and a mild detergent, then wipe dry.

Interior

Grease and condensate water can build up on the inside around the metal grease filters.

- ▶ Clean using a clean, damp cloth and a mild detergent, or a soft brush as needed, then dry well using kitchen towel.

4.2 Metal grease filters

The metal grease filters should be cleaned at least every two months with normal use (more frequently with intensive use) and whenever the saturation indicator alarm is triggered. If properly cared for, the grease filters should provide years of service.

Removing

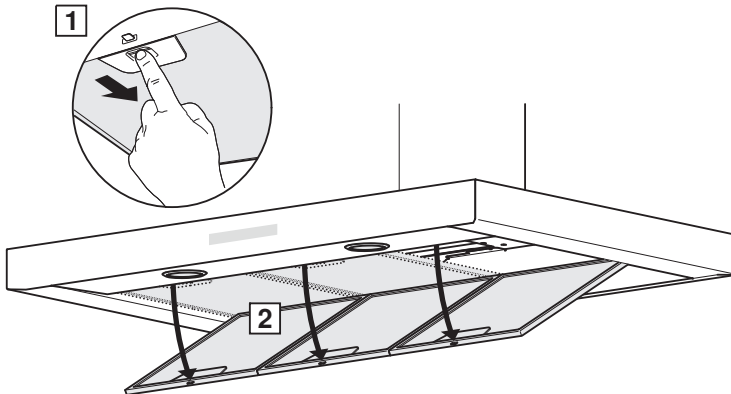

- ▶ Push the lock on the metal grease filter **1** back.
- ▶ Remove the grease filter down and out of the fixture **2**.

Cleaning

- ▶ Clean the grease filters in the dishwasher. Select the «intensive» dishwasher programme with a warm prewash. If no dishwasher is available: Soak the metal grease filters in hot water and mild detergent.
- ▶ Clean, rinse well with clean cold water and then wipe dry.
 - Grease filters can be used again after being cleaned.
- ▶ Put the metal grease filters back.
- ▶ Reset saturation indicator alarm (see page 18).

 Cleaning may cause the metal grease filters to become slightly discoloured. However, this will not affect the functioning of the filters in any way.

4.3 Standard activated charcoal filter

The standard activated charcoal filter needs replacing after an operating period of 3 to 6 months and whenever the saturation indicator alarm is triggered. Standard activated charcoal filters cannot be washed or regenerated.

Removing

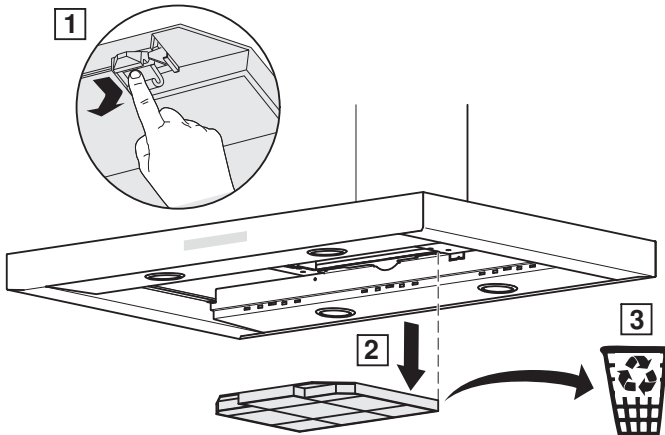

- ▶ Remove the metal grease filters.
- ▶ Push the bar **1** and move the activated charcoal filter down and out **2**.
- ▶ Dispose of spent activated charcoal filters at a suitable recycling point **3** and replace.
- ▶ Reset saturation indicator alarm (see page 18).

4.4 Long-life activated charcoal filters

The long-life activated charcoal filter should be cleaned and reactivated every 3 to 6 months and whenever the saturation indicator alarm is triggered. Depending on intensity of use, do not exceed 5–8 regeneration cycles. If properly cared for, the service life of the long-life activated charcoal filter is up to 3 years.

Removing/Cleaning and regenerating

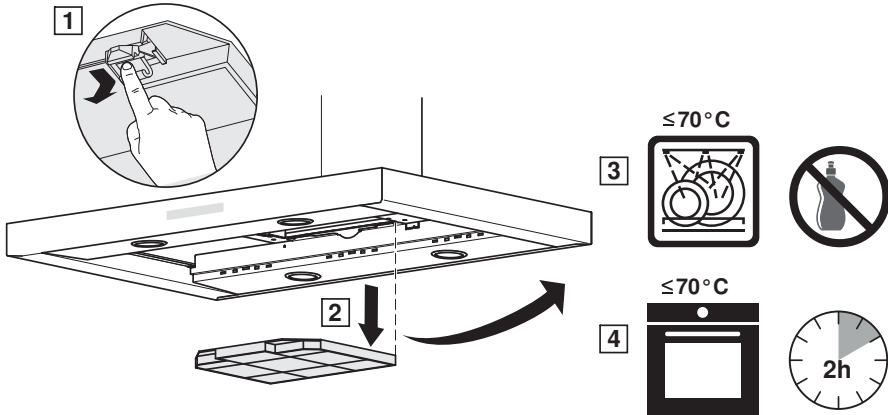

- ▶ Remove the metal grease filters.
- ▶ Push the bar **1** and move the long-life activated charcoal filter down and out **2**.
- ▶ Clean the activated charcoal filter in the dishwasher **3** at max. 70 °C. Do not use detergent. Wash separately so that no food debris can become stuck to the activated charcoal filter. If no dishwasher is available: Soak the activated charcoal filter in water in the sink and rinse well afterwards with clean cold water.
- ▶ Then allow the activated charcoal filter to dry in a vertical position at room temperature or in the oven at max. 70 °C for two hours **4**.

⚠ After heat regeneration in the oven, allow the activated charcoal filter to cool down before putting it back in the range hood. Risk of burns!

- ▶ Reset saturation indicator alarm (see page 18).
- ▶ Dispose of activated charcoal filters that are spent and no longer able to be recycled at a suitable recycling point.

4.5 Reset saturation indicator alarm

Reset the saturation indicator alarm for the metal grease filter **FG** / activated charcoal filter **FC** after cleaning/replacing.

- ▶ With the appliance switched off and the illumination off, hold the  button depressed for three seconds.
 - The saturation indicator **FF** flashes **three times** and then **FG** / **FC** goes out if reset correctly.

4.6 Replacing the LED light bulbs

For safety reasons, the LED light bulbs must be replaced by our Customer Services.

5 Trouble-shooting

This section lists faults that can be solved simply by following the instructions given. If the fault cannot be remedied, please call Customer Services.
 Before calling Customer Services: Please note down the serial number (for SN, see identification plate under «Technical data») and what led to the fault.

Malfunction	Possible cause	Solution
Appliance is not working.	<ul style="list-style-type: none"> ▪ Interruption in the power supply. 	<ul style="list-style-type: none"> ▶ Check the power supply. ▶ Change the fuse. ▶ Reset the automatic circuit breaker.
Illumination is not working.	<ul style="list-style-type: none"> ▪ LED light bulb is defective. 	<ul style="list-style-type: none"> ▶ Contact Customer Services.

Malfunction	Possible cause	Solution
Appliance is not extracting enough air.	<ul style="list-style-type: none"> ▪ Metal grease filters are dirty. 	<ul style="list-style-type: none"> ▶ Clean metal grease filters.
	<ul style="list-style-type: none"> ▪ Recirculation mode only: Activated charcoal filters are saturated. 	<ul style="list-style-type: none"> ▶ Clean and reactivate or replace activated charcoal filters.
	<ul style="list-style-type: none"> ▪ Extraction mode only: Insufficient fresh air intake. 	<ul style="list-style-type: none"> ▶ Ensure fresh air intake is sufficient.

6 Accessories and spare parts

Please give product family of the appliance and exact designation of the accessory or spare part when ordering parts.

Metal grease filter

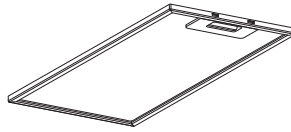

Long-life activated charcoal filter



Standard activated charcoal filter



Remote control



7 Technical data

Electrical connection

Accessing the identification plate:

- ▶ Remove the metal grease filters.
- The identification plate is located on the inside of the appliance.
- A second identification plate is included in the scope of delivery and should be retained for the purpose of appliance identification.

7.1 Product fiche

In accordance with EU Regulation No. 65/2014 and No. 66/2014.

Description	Abbreviations	Unit	Value
Brand	S	-	V-ZUG LTD
Model identifier	M	-	63014 / 62019-21
Annual Energy Consumption	AEC _{hood}	kWh/a	43.3 / 41.7
Energy Efficiency Index	EEI _{hood}	%	41.6 / 40.5
Energy Efficiency Class	EEC	-	A+ / A+
Fluid Dynamic Efficiency	FDE _{hood}	%	35.0 / 35.0
Fluid Dynamic Efficiency Class	FDEC	-	A / A
Lighting Efficiency	LE _{hood}	lux/W	68 / 109
Lighting Efficiency Class	LEC	-	A / A
Grease Filtering Efficiency	GFE _{hood}	%	85.1 / 85.1
Grease Filtering Efficiency Class	GFEC	-	B / B
Air flow at minimum speed	Q _{min}	m ³ /h	300 / 300
Air flow at maximum speed (intensive or boost excluded)	Q _{max}	m ³ /h	580 / 580
Air flow at intensive or boost setting	Q _{boost}	m ³ /h	700 / 700
Airborne acoustical A-weighted Sound Power Emissions at minimum speed	SPE _{min}	dBA	52 / 52
Airborne acoustical A-weighted Sound Power Emissions at maximum speed	SPE _{max}	dBA	66 / 66
Airborne acoustical A-weighted Sound Power Emissions at intensive or boost setting	SPE _{boost}	dBA	69 / 69
Measured power consumption of off mode	P ₀	W	0.49 / 0.49
Measured power consumption of standby mode	P _s	W	- / -
Time increase factor	f	-	0.7 / 0.7
Measured air flow rate at the best efficiency point	Q _{BEP}	m ³ /h	428.5 / 428.5
Measured air pressure at the best efficiency point	P _{BEP}	PA	461.0 / 461.0
Measured value of the electric power input at the best efficiency point	W _{BEP}	W	157.0 / 157.0
Nominal power of the lighting system	W _L	W	4.4 / 2.2

Average illumination of the lighting system over the cooking surface	E_{middle}	lux	300 / 240
Sound power level	L_{wa}	dBA	66 / 66

8 Disposal

8.1 Packaging



Never allow children to play with packaging material due to the danger of injury or suffocation. Store the packaging material in a safe location or dispose of it in an environmentally-friendly way.

8.2 Safety

Render the appliance unusable to prevent accidents caused by improper use (e.g. through children playing):

- ▶ Disconnect the appliance from the mains. With a fixed appliance, this is to be carried out by a qualified electrician. Then cut the mains cable off flush with the appliance.

8.3 Disposal



- The «crossed out wheeled bin» symbol requires the separate collection of waste electrical and electronic equipment (WEEE). Such equipment can contain hazardous, environmentally harmful materials.
- These appliances are to be handed over to a designated collection point for the recycling of electrical and electronic equipment and must not be disposed of with unsorted household waste. And in this way, you will be helping to protect resources and the environment.
- For more information, please contact the local authorities.

Index

A	
Accessories	19
After-running time.....	11
Appliance configuration.....	10
Appliance description	8
Appliance disposal	21
Appliance installation	5
C	
Care and maintenance	15
Changing power level.....	11
With remote control.....	14
CleanAir function.....	12
Cleaning	
Activated charcoal filters.....	16
Housing	15
Long-life activated charcoal filter	
.....	17
Metal grease filters.....	15
Construction.....	8
D	
Disposal.....	21
E	
Electrical connection	19
Equipment	8
Extraction mode	8
I	
Identification plate.....	19
Illumination	10
With remote control.....	13
Initial set-up.....	6
Intensive level	11
With remote control.....	14
M	
Model designation	2
O	
Operating and display elements.....	9
Operating the appliance.....	10
P	
Product fiche.....	21
R	
Recirculation mode	8
S	
Safety precautions	
Before using for the first time.....	6
Correct use	6
Instructions for use.....	6
Note on use	6
Safety warnings	
Appliance installation.....	5
Appliance-specific	5
General	4
Saturation indicator.....	12
Selecting light intensity	10
Service & Support.....	23
Spare parts	19
Switching appliance on/off	10
With remote control.....	13
Symbols.....	4
T	
Technical data	19
Technical questions.....	23
Trouble-shooting	18
Type.....	2
V	
Validity.....	2
W	
Warranty extensions.....	23

9 Service & Support



The «Trouble-shooting» section gives you valuable tips on how to deal with minor malfunctions yourself, saving you the time and trouble of calling out a service technician and any cost that goes along with it.

Information on the V-ZUG warranty can be found at www.vzug.com →Service →Warranty information. Please read this information carefully.

Please register your appliance straightaway online at www.vzug.com →Service →Warranty registration. This will allow you to take advantage of the best possible support in the event of a fault in the appliance during the guarantee period. You will require the serial number (SN) and appliance designation to register your appliance. You will find them on the identification plate of your appliance.

My appliance information:

SN: _____ **Appliance:** _____

Please have this appliance information to hand when contacting V-ZUG. Thank you.

- ▶ Remove the metal grease filters.
 - The identification plate is located on the inside of the appliance.
 - A second identification plate is included in the scope of delivery and should be retained for the purpose of appliance identification.

Your repair order

At www.vzug.com →Service→Service number you will find the telephone number of your nearest V-ZUG service centre.









Technical questions, accessories, warranty extensions

V-ZUG is happy to help you with any general administrative or technical queries, to take your orders for accessories and spare parts and to inform you about our progressive service agreements.

Quick instructions



Buttons

-  Switch appliance on/off
-  Decrease power level
-  Increase power level
-  Intensive power level; alarm for activated charcoal filter on/off
-  CleanAir function; reset saturation indicator
-  After-running time; activate remote control
-  High intensity illumination
-  Low intensity illumination

Display field

- 03** Power level (1–3)
- HI** Intensive level
- FC** Switch between extraction/recirculation mode; alarm for activated charcoal filter on/off
- 24** CleanAir function active
- FF** Reset saturation indicator alarm
- FG** Saturation indicator for metal grease filters
- FC** Saturation indicator for activated charcoal filter (recirculation mode only)
- IR** Remote control on/off



1058018-04